



# American Opto Plus LED L513QPGC-30D

5mm Dia LED LAMP – Water Clear

- ◆ 5.0mm DIA LED LAMP
- ◆ I.C. COMPATIBLE
- ◆ LOW POWER CONSUMPTION
- ◆ LONG LAMP LIFE

## DESCRIPTION

- Round type
- T1-3/4 (5mm) diameter
- Lens color: Water Clear
- With flange
- Solder leads without stand-off

## FEATURES

- Emitted color: Green
- Technology: GaN
- Viewing angle: 30°
- Peak wavelength  $\lambda_p = 523\text{nm}$

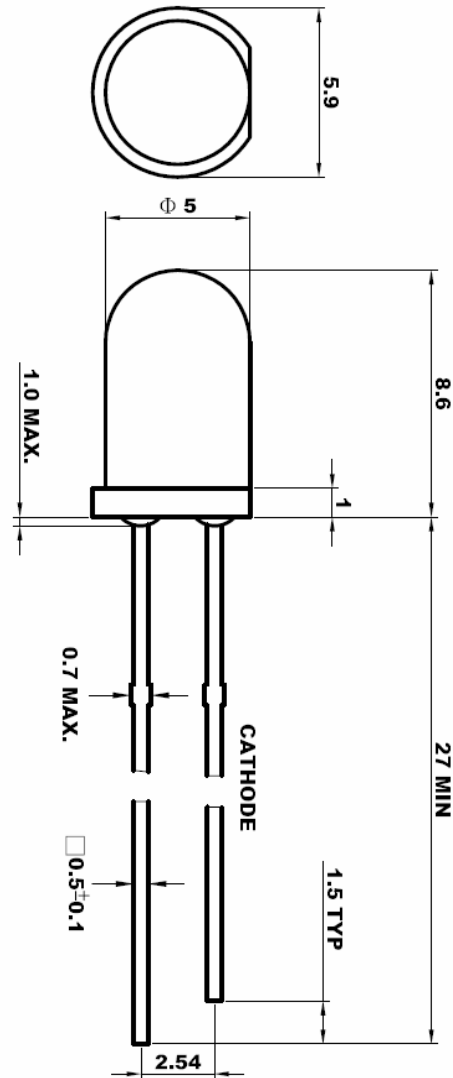

## SELECTION GUIDE

Chip Material	Chip Emitted	Lens Color	Viewing Angle
GaN	Green	Water Clear	30°



# American Opto Plus LED

## L513QPGC-30D

5mm Dia LED LAMP – Water Clear

- ◆ 5.0mm DIA LED LAMP
- ◆ I.C. COMPATIBLE
- ◆ LOW POWER CONSUMPTION
- ◆ LONG LAMP LIFE

### ABSOLUTE MAXIMUM RATINGS

(Ta=25°C)

Parameter	Symbol	Max Rating	Unit
Power Dissipation	$P_D$	120	mW
Peak Forward Current (1/10 Duty Cycle @1KHz )	$I_{PF}$	100	mA
Forward Current	$I_F$	30	mA
Reverse Voltage	$V_R$	5.0	V
Operating Temperature Range	$T_{OPR}$	-40~+85	°C
Storage Temperature Range	$T_{STG}$	-40~+85	°C

Solder temperature 2 mm from body for 3 seconds at 260°C

### OPTICAL-ELECTRICAL CHARACTERISTICS

Parameter	Symbol	Test Condition	Min	Typ	Max	Unit
Luminous Intensity	$I_V$	$I_F = 20mA$	1100	1600		mcd
Forward Voltage	$V_F$	$I_F = 20mA$		3.5	4.0	V
Reverse Current	$I_R$	$V_R = 5V$			10	uA
Viewing Angle	2θ1/2	$I_F = 20mA$		30		deg.
Peak Wavelength	$\lambda_P$	$I_F = 20mA$		523		nm
Dominant Wavelength	$\lambda_D$	$I_F = 20mA$		525		nm
Spectrum Radiation Bandwidth	$\Delta\lambda$	$I_F = 20mA$		36		nm



# American Opto Plus LED L513QPGC-30D

5mm Dia LED LAMP – Water Clear

- ◆ 5.0mm DIA LED LAMP
- ◆ I.C. COMPATIBLE
- ◆ LOW POWER CONSUMPTION
- ◆ LONG LAMP LIFE

## TYPICAL ELECTRO-OPTICAL CHARACTERISTIC CURVES

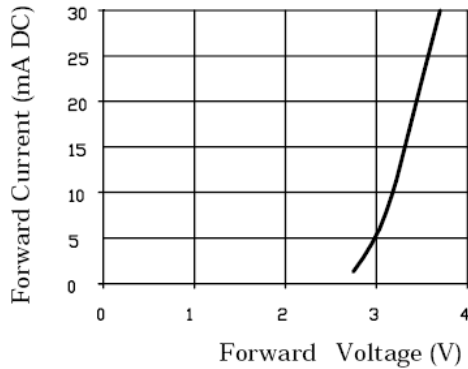

Forward Current Vs.  
Forward Voltage

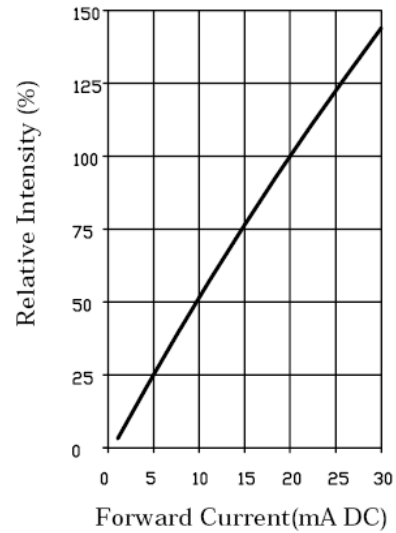

Relative Intensity Vs.  
Forward Current

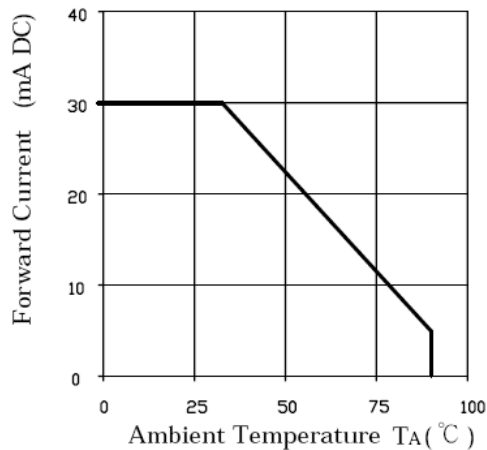

Forward Current  
Derating Curve

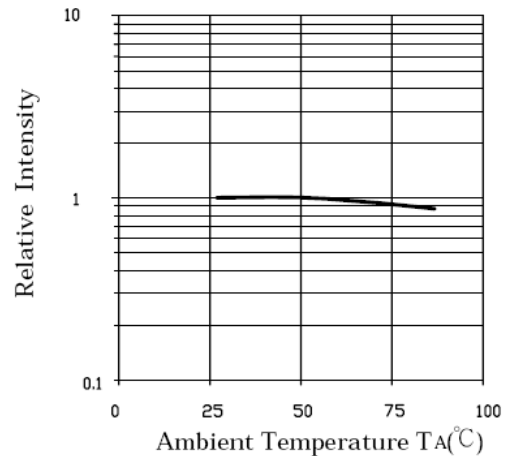

Luminous Intensity Vs.  
Ambient Temperature